

REAR ACCESS PANEL
STEEL OR CLEAR LEXAN

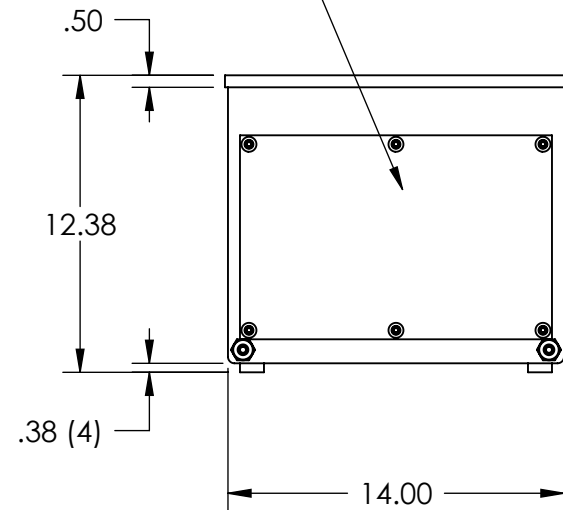

PLAIN CABINET

LATCH PACKAGE

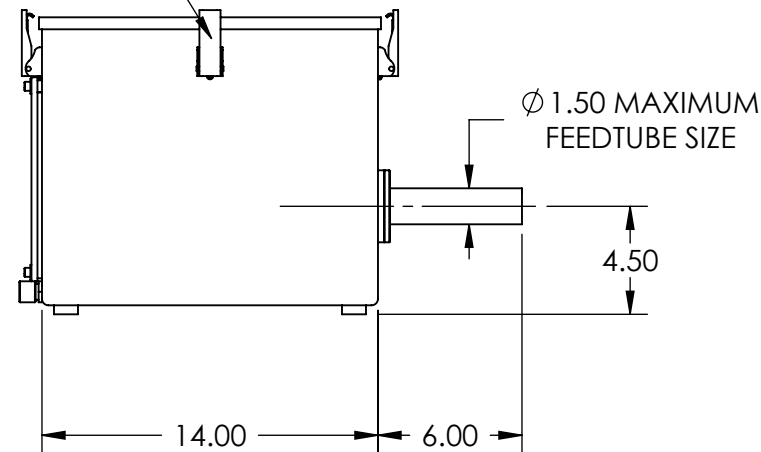

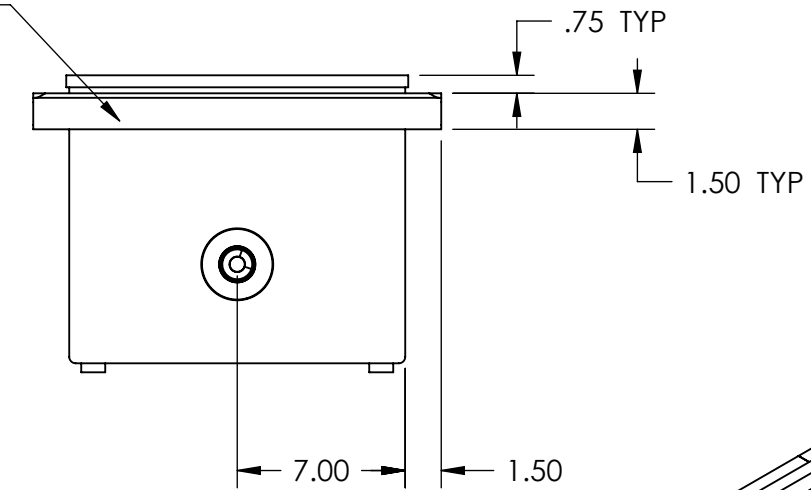

LATCH PACKAGE CABINET

BOLT PACKAGE

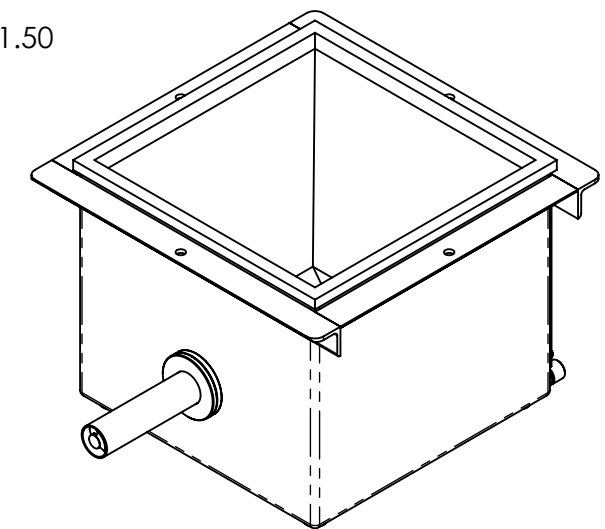
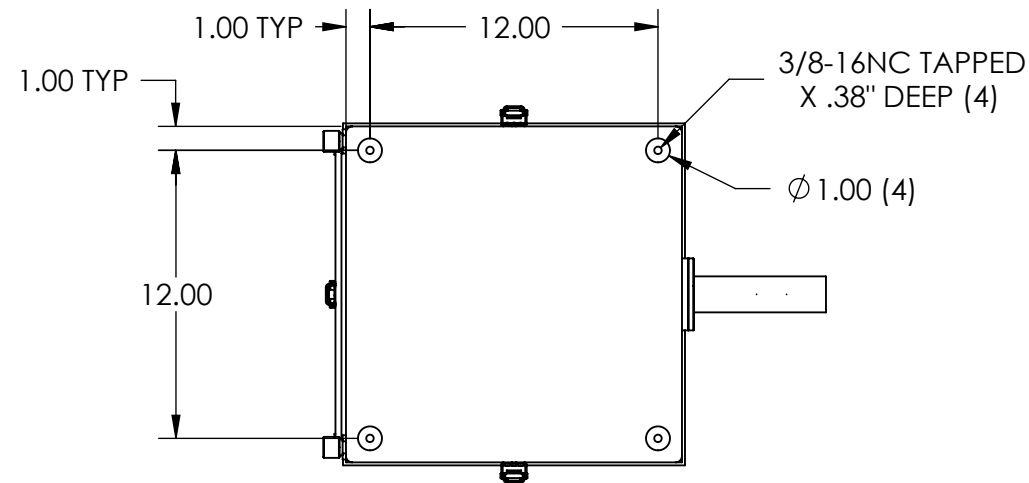

BOLT PACKAGE CABINET



UNLESS OTHERWISE SPECIFIED DIMENSIONS ARE IN INCHES, TOLERANCES ARE:		CAD DRAWING, DO NOT MANUALLY UPDATE		 1811 Buerkle Rd., St. Paul, MN 55110	
WELDMENTS ASSEMBLIES		THIRD ANGLE PROJECTION			
DECIMALS .XX ± .06	ANGLES ± 1.0	DATE 9/11/2008	TITLE: OUTLINE DIMENSIONS O5 SERIES	DRAWN RSD	
DECIMALS .XXX ± .032	ANGLES ± 0.63	CHECKED	APPROVED	DATE	
THE INFORMATION CONTAINED IN THIS DRAWING IS THE SOLE PROPERTY OF TECNETICS INDUSTRIES INC. ANY REPRODUCTION IN PART OR WHOLE WITHOUT THE WRITTEN PERMISSION OF TECNETICS INDUSTRIES INC. IS STRICTLY PROHIBITED.				DO NOT SCALE FROM DRAWING	
SIZE B		DRAWING NUMBER 30020000		REV	
SCALE 1:8		SHEET 1 OF 2			

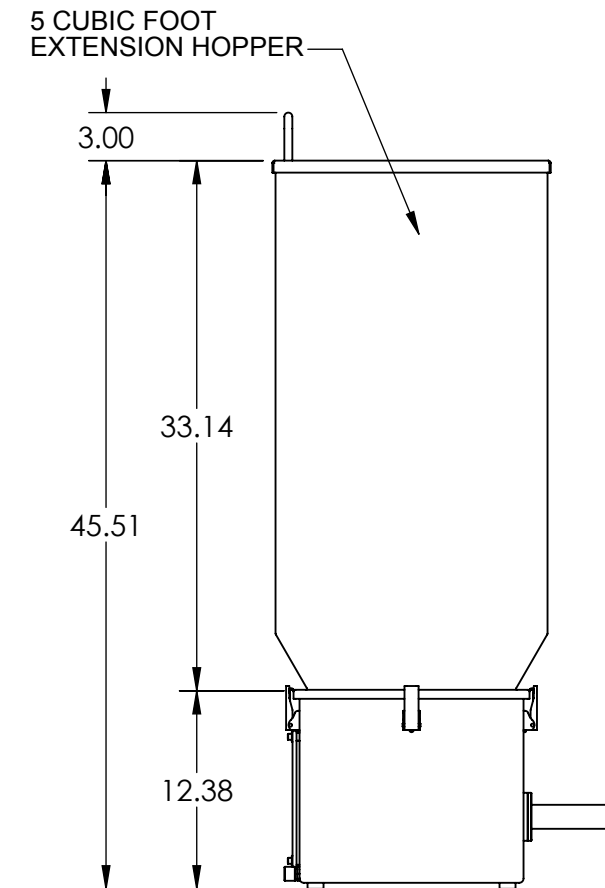
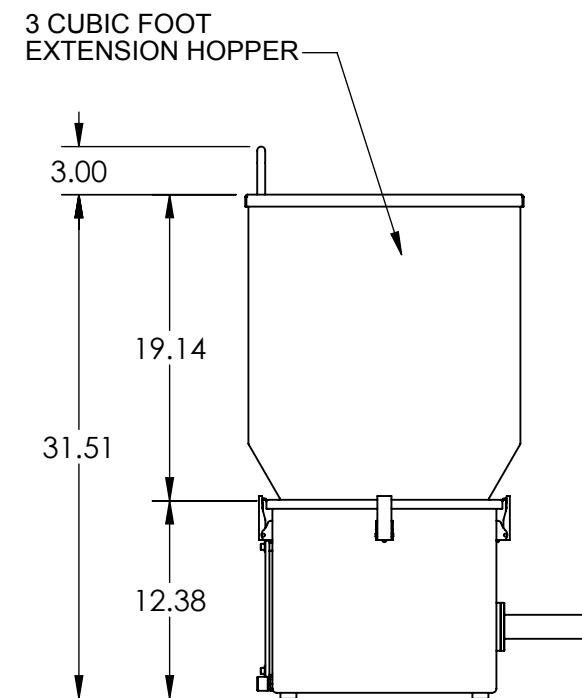
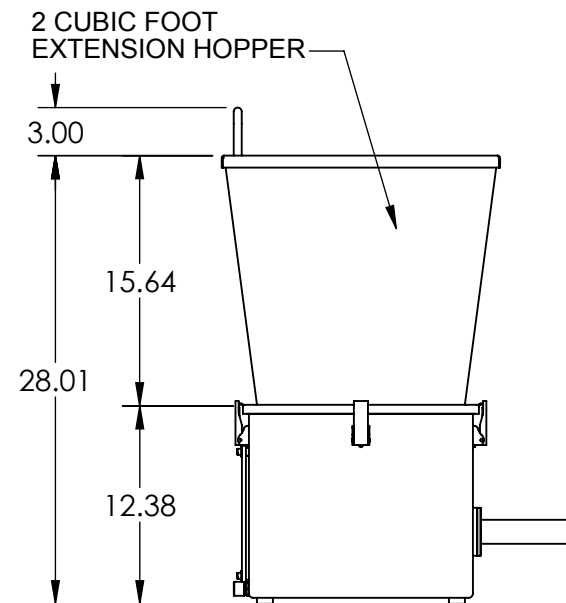
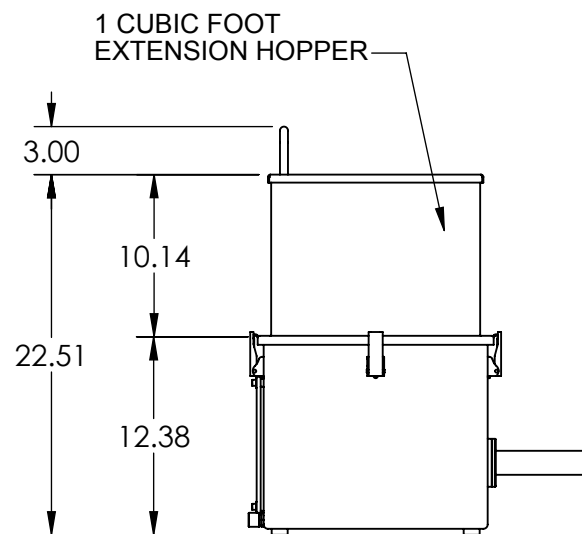
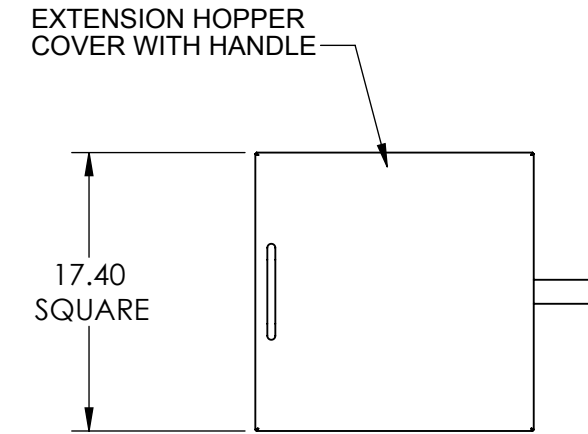
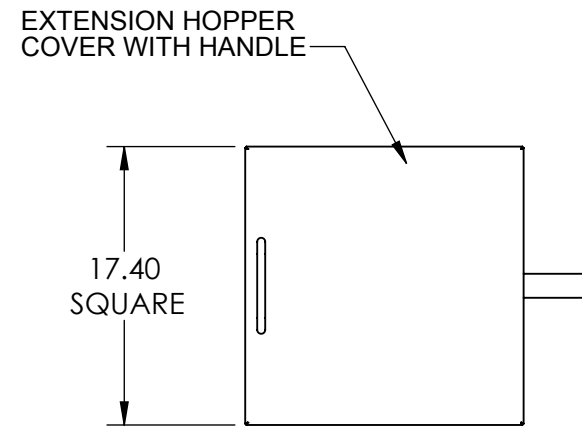
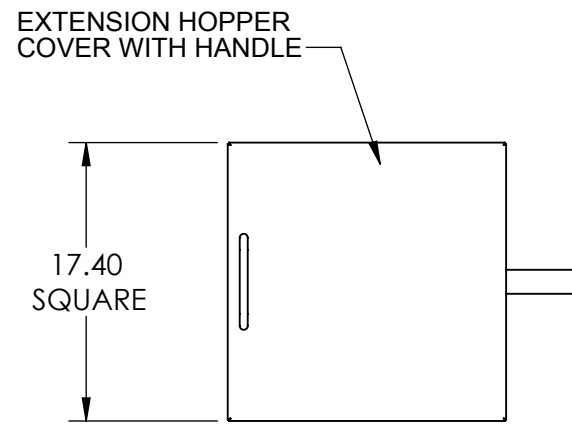
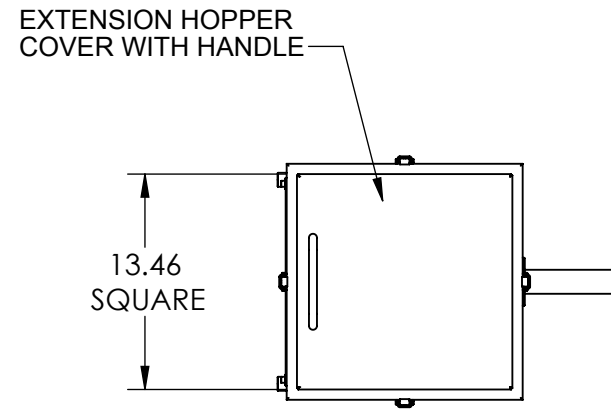

UNLESS OTHERWISE SPECIFIED DIMENSIONS ARE IN INCHES, TOLERANCES ARE:		CAD DRAWING, DO NOT MANUALLY UPDATE		 1811 Buerkle Rd., St. Paul, MN 55110
WELDMENTS ASSEMBLIES		THIRD ANGLE PROJECTION		
DECIMALS .XX ± .06	ANGLES ± 1.0	DATE 9/11/2008	TITLE: OUTLINE DIMENSIONS O5 SERIES	
DECIMALS .XXX ± .032	ANGLES ± 1.0	DRAWN RSD		
THE INFORMATION CONTAINED IN THIS DRAWING IS THE SOLE PROPERTY OF TECNETICS INDUSTRIES INC. ANY REPRODUCTION IN PART OR WHOLE WITHOUT THE WRITTEN PERMISSION OF TECNETICS INDUSTRIES INC. IS STRICTLY PROHIBITED.		CHECKED		
		APPROVED		
		DO NOT SCALE FROM DRAWING	SIZE B	DRAWING NUMBER 30020000
			SCALE 1:12	REV SHEET 2 OF 2